

USE THIS MANUAL FOR PART #'s:
F-RNGR2 / F-RNGR2-G / F-RNGR2-T / F-RNGR2-W / F-RNGR2-C

MANDATORY

LEAVE THIS MANUAL WITH OWNER

Read and follow all instructions.
Lift safety can only be ensured if the lift is installed and operated according to these instructions.

• FOR SAFETY REASONS

- **NEVER** swim alone
- **NEVER** use the lift with a dry pool
- **NEVER** apply direct water pressure to the electronics
- **NEVER** permit children to play on or around the lift
- **DO NOT** allow children to use the lift without adult supervision

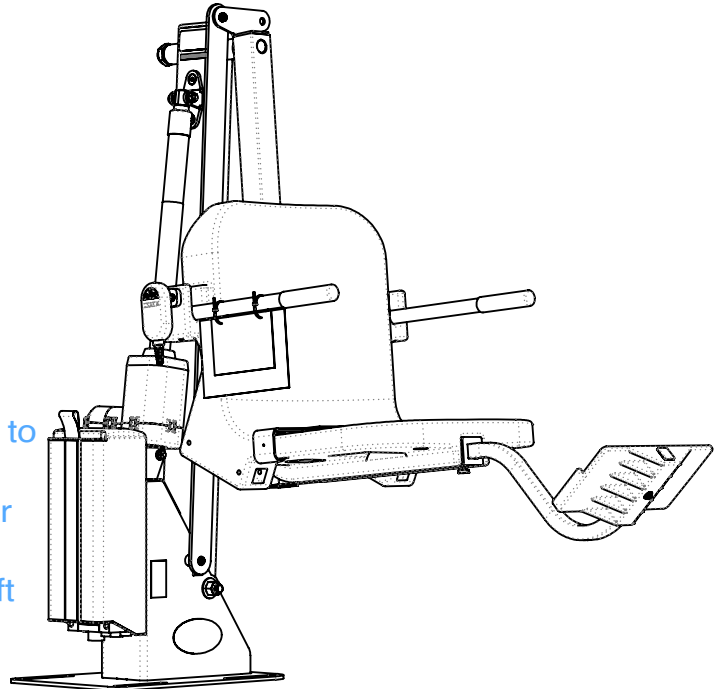

READ CAREFULLY

Check entire box and all packing materials for parts. Before beginning assembly, read the instructions and identify parts using the figures and parts listed in this document.

It is critical that all parts be carefully inspected prior to installation. If any damage occurred in transit, Aqua Creek Products, LLC must be notified within three days of receipt of unit.

Proper installation cannot be overstressed, as an improper installation voids Aqua Creek's warranty and may affect the safety of the user.

**FOR INDOOR OR OUTDOOR USE*



Aqua Creek Products, LLC

9889 Garrymore Lane
Missoula, MT 59808
Toll Free: (888) 687-3552
Local/Intnl: (406) 549-0769
www.aquacreek.com

RANGER 2 - INV01538				
ITEM	PART NO.	QTY.	REV.	DESCRIPTION
1	FRAME ASSEMBLY COMPONENTS			
2	INV03034	1	P1	ASSEMBLY - MAIN FRAME
3	INV03064	1	P1	ASSEMBLY - LIFTING ARM
4	INV02998	1	1	ASSEMBLY - ACTUATOR BRACKET
5	INV03067	1	P1	ASSEMBLY - CONTROL ARM
6	INV01465	1	P1	ACTUATOR - LINAK - 400MM
7	SEAT ASSEMBLY COMPONENTS			
8	INV03065	1	P1	ASSEMBLY - SEAT CRADLE
9	INV00439	1	P1	BRB - 3/8"x1/2"x3/16" - BRONZE BUSHING
10	INV00746	1	P1	NNJ - 1"-8 NYLOCK JAM NUT
11	INV01417	1	P1	ASSEMBLY - SEAT 18.00" - BLUE
12	INV01903	1	P1	ACCESSORY - FOOTREST - BLUE
13	MISCELLANEOUS COMPONENTS			
14	INV03286	1	1	STOCK BOX - LINAK

(14) STOCK BOX - LINAK (NOT SHOWN)

STOCK BOX - LINAK COMPONENTS			
ITEM	PART NO.	QTY.	DESCRIPTION
1	INV00104	1	COVER - LINAK BOTTOM (JUMBO)
2	INV00249	1	SILICONE - BLISTER PACKET - 6 GRAMS
3	INV00340	1	BATTERY - LINAK 24V - 2PC
4	INV00514	1	CHARGER - LINAK - 24V ACP
5	INV00534	1	CHAIR - SEAT BELT
6	INV00578	1	SIGN - "ADA LIFT AVAILABLE" (AQUA CREEK)
7	INV00646	1	LABEL #133 - PROP 65 (BATTERY)
8	INV00716	1	BRACKET - LINAK MOUNT (WALL)
9	INV01804	1	LABEL #146 - DAILY CHARGE

RANGER 2 COLOR OPTIONS:		
CATALOG NO.	PLASTIC COLOR	POWDER COATING COLOR
F-RNGR2	BLUE	WHITE
F-RNGR2-G	GRAY	WHITE
F-RNGR2-T	TAN	WHITE
F-RNGR2-W	WHITE	WHITE
F-RNGR2-C	CUSTOM	CUSTOM

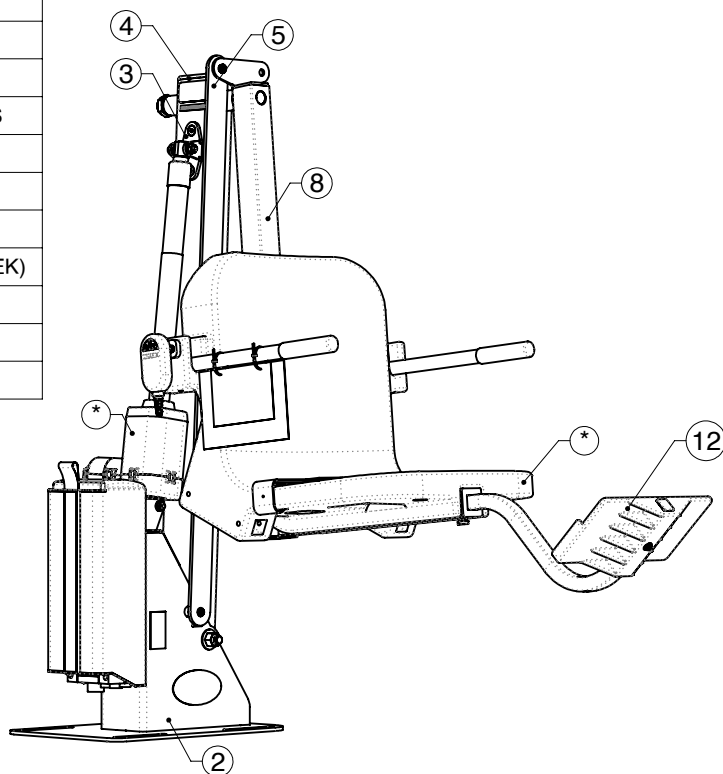

For Service and/or replacement parts, contact Aqua Creek Products, LLC.
 Toll Free: (888) 687-3552 Local/Intnl: (406) 549-0769 www.AquaCreek.com



Aqua Creek Products

Leaders in Recreation, Fitness and Ability

PRODUCT ORDER FORM

RANGER 2 - INV01538

PART NO.	QTY.	REV.	DESCRIPTION	REPLACEMENT PARTS
INV03034	1	P1	ASSEMBLY - MAIN FRAME	
INV03064	1	P1	ASSEMBLY - LIFTING ARM	
INV02998	1	1	ASSEMBLY - ACTUATOR BRACKET	
INV03067	1	P1	ASSEMBLY - CONTROL ARM	
INV03073	1	P1	ACTUATOR - LINAK - 400MM - 90DEG	
INV03065	1	P1	ASSEMBLY - SEAT CRADLE	
INV00000	1	P1	ASSEMBLY - SEAT 18.00" - LABELS	<input type="checkbox"/> BLUE <input type="checkbox"/> GRAY <input type="checkbox"/> TAN <input type="checkbox"/> WHITE
INV01903	1	P1	ACCESSORY - FOOTREST - BLUE	<input type="checkbox"/> BLUE <input type="checkbox"/> GRAY <input type="checkbox"/> TAN <input type="checkbox"/> WHITE
INV00340	1	P1	BATTERY - LINAK 24V - 2PC	
INV00715	1	P1	BRACKET - LINAK MOUNT	
INV00439	1	P1	BRB - 3/8"x1/2"x3/16" - BRONZE BUSHING	
INV00471	3	P1	BSH - #10-24x3/8" SOCKET HEAD BOLT	
INV02389	1	P1	CONTROL BOX - LINAK 2 PORT - 10 AMP	
INV00588	1	P1	COVER - UNIVERSAL BATTERY - BLUE	<input type="checkbox"/> BLUE <input type="checkbox"/> GRAY <input type="checkbox"/> TAN
INV00646	1	P1	LABEL #133 - PROP 65 (BATTERY)	
INV01804	1	P1	LABEL #146 - DAILY CHARGE	
INV00746	1	P1	NNJ - 1"-8 NYLOCK JAM NUT	
INV01846	1	P1	REMOTE - 2 BUTTON LINAK	
INV03286	1	1	STOCK BOX - LINAK	

For Service and/or replacement parts, contact Aqua Creek Products, LLC.
 Toll Free: (888) 687-3552 Local/Intnl: (406) 549-0769 www.AquaCreek.com



Aqua Creek Products

— Leaders in Recreation, Fitness and Ability —

PRODUCT ASSEMBLY

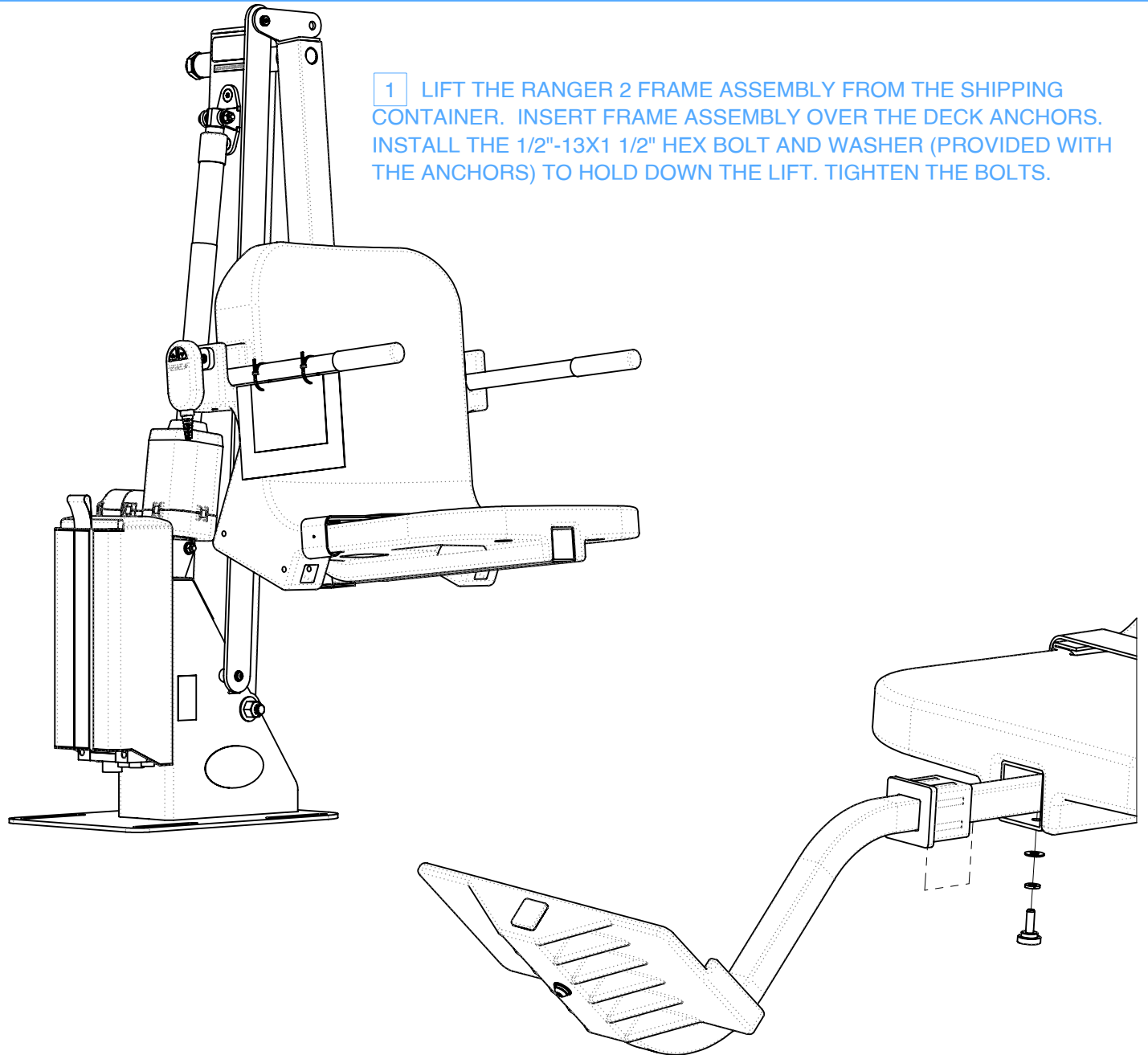

1 LIFT THE RANGER 2 FRAME ASSEMBLY FROM THE SHIPPING CONTAINER. INSERT FRAME ASSEMBLY OVER THE DECK ANCHORS. INSTALL THE 1/2"-13X1 1/2" HEX BOLT AND WASHER (PROVIDED WITH THE ANCHORS) TO HOLD DOWN THE LIFT. TIGHTEN THE BOLTS.

2 THE AQUA CREEK FOOTREST ASSEMBLY IS DESIGNED TO FIT UNDER THE CHAIR AND IS INSTALLED INSIDE THE 2" SQUARE TUBING THAT SUPPORTS THE SEAT FROM UNDERNEATH. TO INSTALL THE FOOTREST; FIG. 06

2 A INSERT THE FOOTREST ASSEMBLY INTO THE 2X2 SQUARE TUBING THAT SUPPORTS THE CHAIR UNTIL THE PLASTIC INSERT OF THE FOOTREST ASSEMBLY SITS FLUSH AGAINST THE END OF THE 2X2 TUBE.

2 B USING THE SUPPLIED 1/4" FASTENERS, FASTEN THE FOOTREST ASSEMBLY TO THE 2X2 TUBING IN THE DESIRED LOCATION.



Aqua Creek Products

Leaders in Recreation, Fitness and Ability

PRODUCT ASSEMBLY

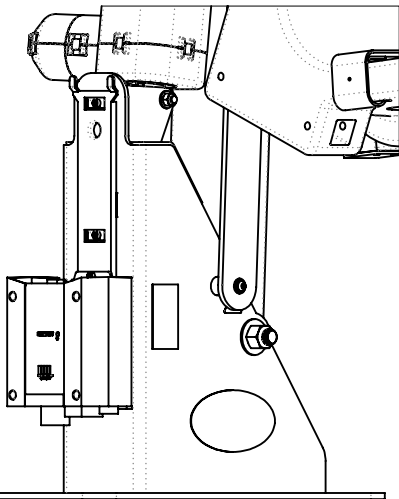

3 REMOVE THE FULLY CHARGED BATTERY FROM THE CHARGER AND INSTALL THE BATTERY TO THE CONTROL BRACKET, ON TOP OF THE CONTROL BOX. ONCE SECURE, CONNECT THE BATTERY CABLE TO THE CONTROL BOX CABLE. THE LIFT WILL ONLY OPERATE WHEN THE BATTERY IS CONNECTED PROPERLY.

WHEN THE LIFT IS NOT IN SERVICE, STORE BATTERY ON THE CHARGER!

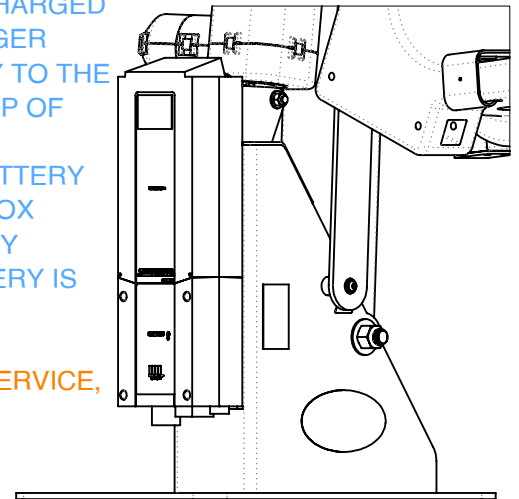

4 WITH THE LIFT FULLY ASSEMBLED AND ANCHORED, RUN THE LIFT COMPLETELY OUT AND BACK IN 3 TO 5 TIMES, WITHOUT WEIGHT, FOR THE LIFTS "BREAK IN" CYCLE PERIOD.

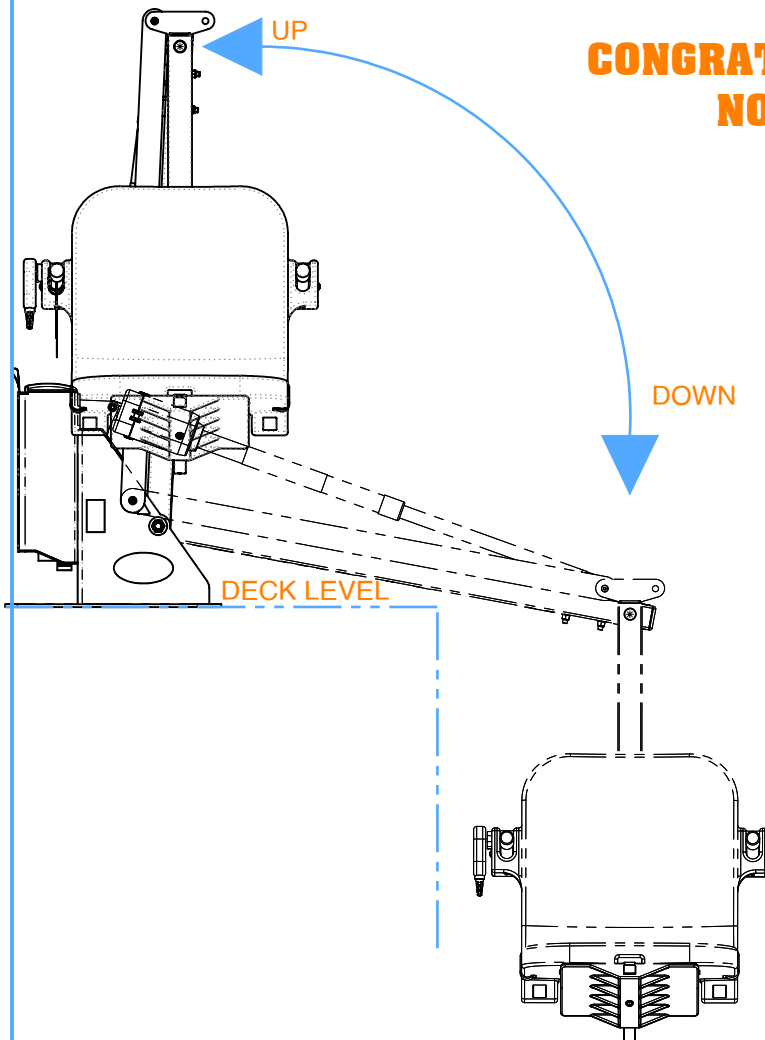

CONGRATULATIONS, YOUR LIFT IS NOW READY FOR USE!

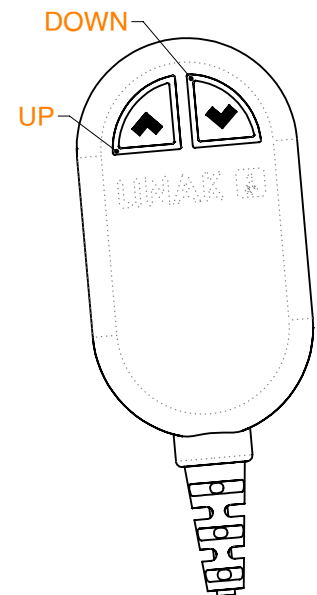

**2-BUTTON
REMOTE FUNCTION**



Aqua Creek Products

—Leaders in Recreation, Fitness and Ability—

IMPORTANT SAFETY INSTRUCTIONS

READ ALL INSTRUCTIONS BEFORE USING



WARNING - To reduce the risk of injury, do not permit children to use this product unless they are closely supervised at all times.

This appliance is not intended for use by persons (including children) with reduced physical, sensory or mental capabilities, or lack of experience and knowledge, unless they have been given supervision or instruction concerning use of the appliance by a person responsible for their safety.

A wire connector is provided on the unit to connect a minimum 8 AWG (8.4mm²) solid copper conductor between this unit and the means for local equipotential bonding.

Check the unit periodically for signs of deterioration: Keep all nuts, bolts and screws tight to be sure the lift is in safe working condition.

SAVE THESE INSTRUCTIONS

Affix supplied ADA POOL/SPA LIFT sign in a location visible from the lift at all times.

Rechargeable batteries are to be removed from the appliance before being charged. Batteries are to be inserted with the correct polarity. If the appliance is to be stored unused for a long period of time, the batteries should be removed and stored on the wall mounted charger to maintain the battery charge. The supply terminals are not to be short-circuited.

REDUCE THE RISK OF DROWNING!

Supervise children at all times.

No jumping or diving from the lift.

Seat may be hot, use caution when entering.

Keep covered when not in use. Inspect and clean before use.

INDOOR BATTERY CHARGER:

AMPERAGE = 0.65 FREQUENCY = 60

24 VOLT BATTERY

AMPERAGE = 10 IP RATING = IPX5

For Service and/or replacement parts, contact Aqua Creek Products, LLC.
Toll Free: (888) 687-3552 Local/Intl: (406) 549-0769 www.AquaCreek.com



Aqua Creek Products

Leaders in Recreation, Fitness and Ability

LIFT INSPECTION

LIFT/INSPECTION INFORMATION

Test Date:	For Additional Support Assistance Call: Toll Free: (888) 687-3552 Local/Intnl: (406) 549-0769
Pool Lift Model:	
Serial Number:	For Additional Online Assistance Visit:
Inspected By:	CLICK HERE or VISIT: www.AquaCreekProducts.com/Help-Center/Troubleshooting
CLICK HERE or VISIT: www.AquaCreekProducts.com	

Maintenance Notes:

Please read and fill out all information carefully

Improper use and/or maintenance of pool lift can lead to actuator and/or other mechanical failures and possible personal injury. Please read and follow the product operators' manual and the instructions below.

NOTE: Completely cycle the lift without a load before each use to verify the lift is functioning properly.

- Product service life depends on the load characteristics, type and frequency of use, and the environment in which the product is being used. For example, persons not calmly sitting but falling down with their full body weight in the chair, or using the pool lift's chair as a diving platform can casue premature actuator failure and/or possible personal injury.
- Based on historical product service life analysis, Aqua Creek recommends replacing the actuator(s) and other electronic components after 5 years of service. Check component serial numbers and purchase records to verify the age of your components.
- A functional weight lifting force of a maximum of 100lbs. Must be periodically verified by applying a non-live load (without a person) through the entire operating cycle of the lift. This process is performed in order to verify the smooth operation. Make note of any unusual noises or sudden movements coming from the actuator(s) or other components. Note: In some lifts, a sudden quick movement at the beginning of the cycle is normal but should smooth out over the course of operation.
- Creating a side load on the actuator by pushing and/or pulling on the actuator, especially under load conditions, can casue damage to the actuator and or personal injury.
- Electronic components are designed to be plug-and-play type replacements. There is no need to access the internal mechanisms in these components. The actuator, battery, and all electronic components may only be disassembled by authorized factory-trained personnel. Disassembly of electronic components by improperly trained and unauthorized persons will void the warranty on those components.
- The operator of the pool lift should never allow the pool lift to hit any stationary object either vertically or horizontally while operating a pool lift, i.e. walls, ceiling, pool/spa bench, etc.
- For quick and accurate troubleshooting and inspections, we recommend having a voltage meter on had as well as adequate test and replacement components for the unit.
- Remove the pool lift from service immediately if any unusual noise is heard coming from the actuator such as grinding, popping or sudden inconsistent movements.
- Immediately remove from service any lift that does not have 100% compliance with the inspection until the appropriate corrections have been made by a qualified person.



Aqua Creek Products

Leaders in Recreation, Fitness and Ability

VISUAL INSPECTION

I. OVERALL VISUAL INSPECTION

Corrosion is common with anything in a swimming pool environment; even stainless steel. Proper and regular maintenance and cleaning will prevent most instances of corrosion. **Replace any components that have corrosion caused pitting, cracking, thinning of the base metal, or other instances of corrosion that can't be eliminated and/or minimized through thorough cleaning.** refer to product manual for additional maintenance instructions. Make comments and/or recommendations in the notes area below each section.

INSPECTION ITEM	PASS	FAIL	N/A
1. Anchor bolts, concrete around anchors, etc... are in good condition. No cracks in concrete, missing hardware, and anchors are installed correctly.			
2. The fixing anchor is installed correctly and is in good condition.			
3. Powder coated components are clean, corrosion free, and in good overall condition. Clean and repair any missing powder coat finish. Apply a coat of wax on the cleaned and repaired finish.			
4. Welded joints show no signs of cracks or fatigue. Replace any non-compliant components.			
5. Hardware is present, secure, and not corroded (bolts, nuts, bushings, etc...).			
6. All wiring routing clips are present and in good condition.			
7. All product warning labels are present and legible.			
8. Plastic seat, foot rest, and other plastic components are present and in good shape.			
9. Armrest hand grips are present, in good condition, and are well secured to the arms.			
10. Electronic and lift covers are present and in good condition (Lift covers are highly recommended for outdoor installations).			
11. Inspect rotation gears for any damage or missing teeth. Inspect rotation motor gear and alignment to ensure proper rotation of the lift.			
12. Inspect lift slings, seat belts, and other similar stitched and webbed or weaved materials for damage, fatigue, and/or deterioration. Replace at first sign of any fatigue or damage.			

NOTES/RECOMMENDATIONS:

Blank area for notes and recommendations.



Aqua Creek Products

—Leaders in Recreation, Fitness and Ability—

PHYSICAL INSPECTION

I. PHYSICAL POOL LIFT TEST

A physical test of the lift function is required when doing an annual inspection. NOTE: The lift should always be run through a completed cycle without a load prior to each use. The annual test should be ran both empty and with a typical load weight to test the lifts functions. Make comments and/or recommendations in the notes area below each section.

INSPECTION ITEM	PASS	FAIL	N/A
1. With all connections connected, operate the lift through a complete cycle without weight to confirm the lift is functioning correctly. Note any strange noises and any unusual operation.			
2. Verify the lift was installed correctly; is the lift free to travel in and out of the pool without hitting anything like a wall, rail, bench, etc...			
3. Rotate lift at least 90 degrees over the water and back again if applicable.			

NOTES/RECOMMENDATIONS:

Large empty rectangular area for handwritten notes and recommendations.



Aqua Creek Products

—Leaders in Recreation, Fitness and Ability—

ELECTRONICS INSPECTION

I. ELECTRONICS INSPECTION

Most electronic issues are due to pool electrical connections and/or a defective battery. Always remove the battery and place on the charger when the lift is not in use. NOTE: Even if your lift is equipped with a solar charger, it is a good idea to place the battery on the wall charger periodically or during extended periods of non-use or storage. Before testing the battery, charge overnight. A voltage meter is required for this section and a known GOOD handset controller is helpful. An Aqua Creek electronics test light is also highly recommended (order item F-01TL). Make comments and/or recommendations in the notes area below each section.

INSPECTION ITEM	PASS	FAIL	N/A
1. Battery contact points are free of damage and/or corrosion. Dielectric grease is present on all contact points to prevent corrosion. ALWAYS STORE BATTERY ON THE CHARGER WHEN LIFT IS NOT IN USE!			
2. Battery level indicator (if equipped) on control box is functioning properly when battery is installed on lift.			
3. Using the voltage meter check the voltage on the battery. A good battery should read between 24v and 28v DC. Note: Vito batteries will require a test cord. (F-VTC002)			
4. Using the test light, confirm continuity through the control box by plugging the light into the control box in place of the actuator and press the buttons on the controller and the control box itself (if applicable). If the light does not light up with the handset, replace handset with a known good one and try to see if it lights up.			
5. Once the battery is fully charged up to 24 to 28 volts, cycle the lift (up, down, rotate) counting the cycles. If the battery is in good condition, the lift should easily complete at least 15 cycles without a load.			

NOTES/RECOMMENDATIONS:



Aqua Creek Products

Leaders in Recreation, Fitness and Ability

PROPER CARE OF LIFTS

PROCEDURE	BEFORE EACH USE	DAILY	WEEKLY	MONTHLY
Check battery level indicator on control box.				
Run the lift through a complete test cycle (fully extend actuator) to verify it is functioning properly.				
Wash lift with fresh water and dry with clean, soft, non-abrasive cloth.				
Recharge battery.				
Visually inspect lift for damage, corrosion, and loose or missing hardware.				
Check all contact points for damage and/or corrosion.				
Repair, clean and apply dielectric grease to all contact points.				
Thoroughly clean lift frame and apply a liberal coat of car wax to maintain the lift's finish.				
Check all Warning and Cautionary labels to make sure they are not faded or worn. Replace as needed.				

PROPER CARE NOTES:

- Use only fresh water to wash your lift. Do not wash with pool water.
- Use only clean, soft, non-abrasive cloths on your lift.
- Do not store lift in pump room or near chemicals.
- Do not allow children to play on or around this lift.
- When cleaning the lift, do not spray water directly on control box or battery.
- The lift may need to be bonded according to local code requirements.
- If the lift is not used for extended periods, remove the battery from the lift and store it on the wall charger to maintain the batteries charge. The charger should be plugged in and in a climate controlled area.

STAIN REMOVAL NOTES:

To remove stubborn stains from finish, spray affected area with mild dish soap, rub briskly with a 3M Scotch Brite™ pad. Use white epoxy paint to touch up the finish. Apply wax to protect when dry.



Aqua Creek Products

—Leaders in Recreation, Fitness and Ability—

LIMITED FIVE (5) YEAR WARRANTY

Aqua Creek Products, LLC (a.k.a. Aqua Creek) warrants to the original end user purchaser that products manufactured by Aqua Creek, when properly installed in accordance with assembly and installation instructions, and properly used and maintained, shall be free from defects in material and workmanship for a period of **five (5) years from the date of original purchase**, provided that Aqua Creek receives prompt notice in writing of any defect or failure and satisfactory proof thereof, with the following exception(s):

Exceptions:

- All electrical components, including the linear actuator shall have the following warranty period:
 - Year 1-2: 100% Coverage
 - Year 3: 60% Coverage (Customer is responsible for 40% of replacement cost)
 - Year 4: 50% Coverage (Customer is responsible for 50% of replacement cost)
 - Year 5: 40% Coverage (Customer is responsible for 60% of replacement cost)
- Hydraulic actuators and mesh slings shall have a warranty period of **one (1) year from the date of original purchase**.
- Powder coat finish scratches, scrapes, corrosion, or dents from customers normal use, negligence, or abuse.

This warranty specifically excludes reimbursement for labor to remove, repair, or install the product and any shipping charges. These warranties do not cover any damages due to accident, force majeure, act of nature, misuse, abuse, negligence or failure to properly maintain any products, or normal wear and tear from day to day operations. In the event that any products are altered, repaired, or improperly installed or improperly used by anyone without the prior written approval by Aqua Creek, all warranties are void. **IMPORTANT: AMOUNT OF WEIGHT PLACED ON LIFT SHALL NOT EXCEED THE RATED LIFTING CAPACITY FOR THE LIFT. NEVER OPERATE THE LIFT UNDER LOAD IN A DRY POOL (WITH NO WATER IN THE POOL).** It is the responsibility of the lift owner to verify the weight of the patron for warranty claim purposes and to ensure that the lift is not overloaded. Non-payment for product to Aqua Creek may void warranty.

To initiate a warranty claim, the owner of an Aqua Creek product must provide the place of purchase, in writing, with a full description of the product, its serial number, the dates of purchase and installation, and the exact nature of the defect. Within thirty (30) days after receipt of a written warranty claim by Aqua Creek, and barring any unforeseen delays, the place of purchase will be notified of Aqua Creek's decision regarding the claim.

If requested by Aqua Creek, any defective product must be returned, freight prepaid by customer, to Aqua Creek's designated factory location or duly appointed distributor for inspection and/or repair. Aqua Creek will, at its option, repair or replace the failed or defective item, and deliver the repaired product or replacement to the customer. All freight charges are the responsibility of the customer. Products returned to Aqua Creek for which Aqua Creek provides replacement under this limited warranty shall become the property of Aqua Creek. A new warranty period shall **NOT** be established for the repaired or replaced products. Such products shall remain under warranty only for the remainder of the original warranty period on the original products purchased.

This written limited warranty constitutes the final, complete and exclusive statement of warranty terms. No person or organization is authorized to make any other specific or implied warranties or representations on behalf of Aqua Creek.

THE WARRANTIES SET FORTH HEREIN ARE IN LIEU OF ALL OTHER WARRANTIES, EXPRESSED OR IMPLIED, WHICH ARE HEREBY DISCLAIMED AND EXCLUDED, INCLUDING WITHOUT LIMITATION ANY WARRANTY OF MERCHANTABILITY OR FITNESS FOR A PARTICULAR PURPOSE OR USE.

THE SOLE AND EXCLUSIVE REMEDIES FOR BREACH OF ANY AND ALL WARRANTIES WITH RESPECT TO THE PRODUCTS SHALL BE LIMITED TO REPAIR OR REPLACEMENT AT AQUA CREEK'S DESIGNATED FACTORY LOCATION, OR DULY APPOINTED DISTRIBUTOR, OR IN PLACE AT AQUA CREEK'S OPTION. IN NO EVENT SHALL AQUA CREEK'S LIABILITY EXCEED THE ENTIRE AMOUNT PAID TO AQUA CREEK BY THE ORIGINAL PURCHASER FOR THE FAILED OR DEFECTIVE PRODUCT. IN NO EVENT SHALL AQUA CREEK PRODUCTS, LLC BE LIABLE FOR ANY INCIDENTAL, CONSEQUENTIAL, SPECIAL, INDIRECT, PUNITIVE OR EXEMPLARY DAMAGES OR LOST PROFITS FROM ANY BREACH OF THIS LIMITED WARRANTY OR OTHERWISE.

THIS WARRANTY GIVES YOU SPECIFIC LEGAL RIGHTS AND YOU MAY ALSO HAVE OTHER RIGHTS, WHICH MAY VARY FROM STATE TO STATE. SOME STATES DO NOT ALLOW THE EXCLUSION OR LIMITATION OF INCIDENTAL, SPECIAL OR CONSEQUENTIAL DAMAGES, SO SOME OF THE ABOVE LIMITATIONS OR EXCLUSIONS MAY NOT APPLY TO YOU.