

SPA LIFT ULTRA

U.S. PATENT NO. D507,769 S

PRODUCT WEIGHT: 180lbs [81kg]
MAX WEIGHT CAPACITY: 400lbs [181kg]
MIN ANCHOR SETBACK: 10"
MIN WALL HEIGHT: 21"
WALL THICKNESS @ MIN HEIGHT: 12"
MAX WALL HEIGHT: 51"
WALL THICKNESS @ MAX HEIGHT: 14"
VERTICAL TRAVEL DISTANCE: 41 1/8"

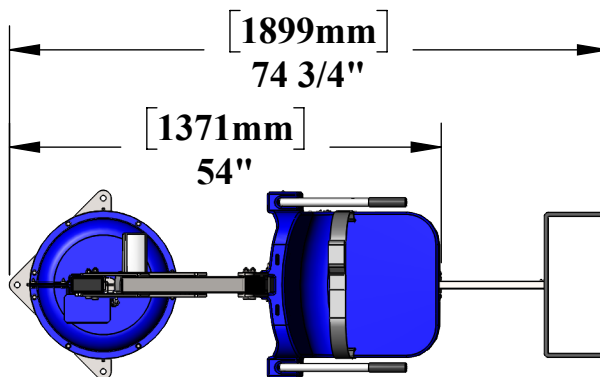
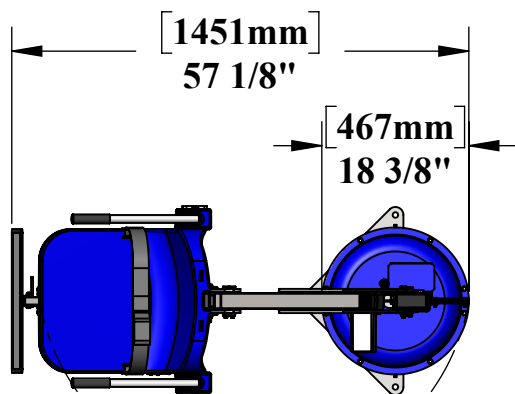
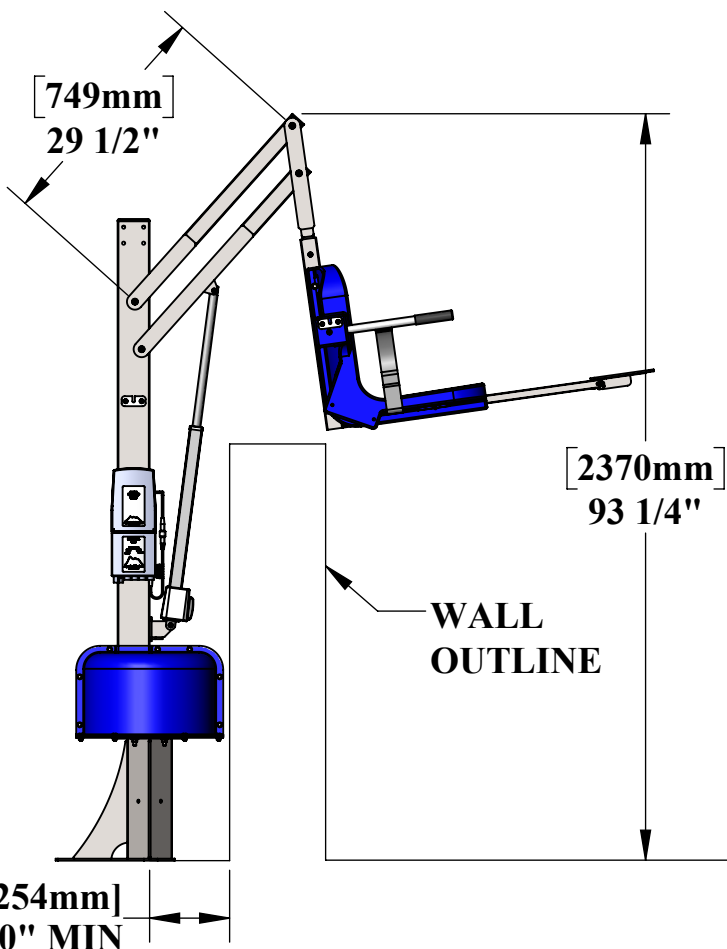
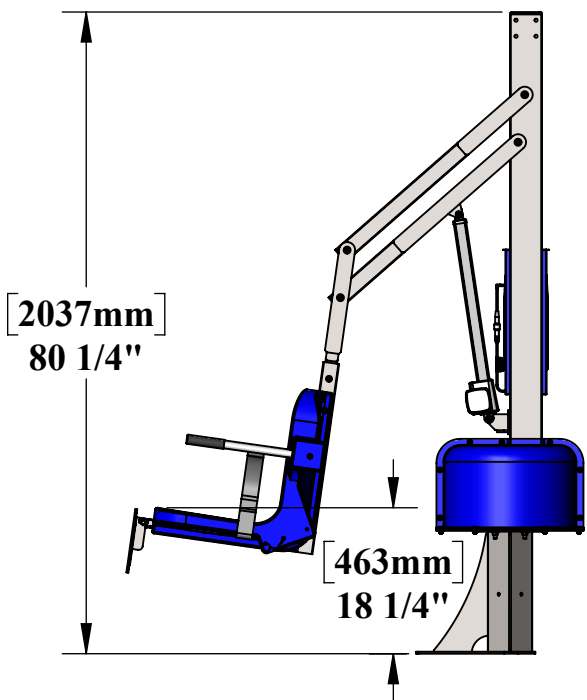

LOADING POSITION

CONTINUOUS 360° ROTATION

ABOVE WALL



9889 GARRYMORE LANE
 MISSOULA, MT 59808
 (406) 549-0769
 FAX (406) 549-2602

NOTE:
 *SPECIFICATIONS ARE SUBJECT TO CHANGE WITHOUT NOTICE

PRODUCT: SPA LIFT ULTRA	
PART #: F-005SLU	
SCALE: 1:24	DATE: 10/5/2018
DRAWN BY: KR	REVISION: B